



REQUIREMENTS

- ❑ **Exterior air barrier and thermal barrier:** A continuous barrier shall be installed in the building envelope. Exterior thermal envelope must be continuous, breaks in air barrier and joints shall be sealed. Fasteners shall be no closer than 6” apart and no farther than 18” on vertical stud lines. Fasteners shall be wrap cap nail or wrap cap screws or staples. Air permeable insulation shall not be used as a sealing material.
- ❑ **Windows:** All insulation shall be in compliance with the Illinois Energy Conservation Code that is in effect. Caulking and Sealants: Exterior joints around windows and door frames shall be insulated with type 1 low expandable (foam). Batt insulation is prohibited. (Ord. 2014-46). Before trim and vinyl siding, windows should be sealed with flashing tape.

The following instructions serve as a basic guide to help you through this process:

1. Apply a strip of self-adhesive flashing tape to the bottom of the window frame. Completely cover any nail heads, as well as the seam between the windows nailing flange, and the home's water resistive barrier.
2. Add strips of flashing tape to both sides of the window, again covering any seams. Extend the flashing tape a few inches above the nailing flange on the top side of the window, and completely cover the ends of the horizontal strip of flashing tape that runs along the bottom edge of the window frame.
3. Apply the final strip of flashing tape along the top of the window, making sure to completely cover the nailing flange, as well as the top edges of the two vertical strips of flashing tape, which you previously installed.
4. Once you have sealed each window with flashing tape, you can install the J-channel trim pieces around each window. Follow the manufacturer's installation instructions that come with the J-channel you purchased. After the J-channel trim pieces are installed around all the windows and doors, you can begin to hang the vinyl siding panels by inserting the end of the siding panels into the J-channel, as you work your way up the wall. In order to accommodate for the expansion and contraction of the siding panels, remember to leave a 1/4-inch gap between the side edge of each panel, and the inside of the J-channel window trim.



Windows, Doors, and Roof Lines

Flashing New Window Installations: If installing both a new window and flashing, refer to window manufacturer's instructions and ASTM E2112, *Standard Practice for Installation of Exterior Windows, Doors and Skylights* for the proper flashing installation method for the window type and wall configuration on the project.

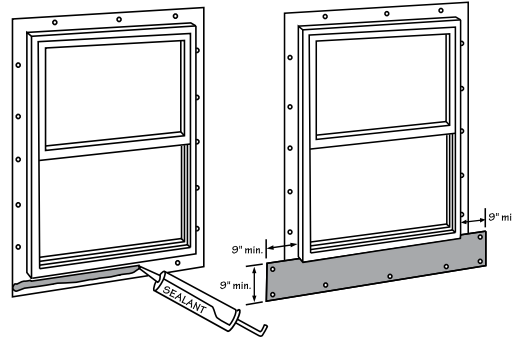

If a nail fin (in new construction) window has been previously installed without flashing, the following instructions should be followed:

Apply a continuous bead of sealant to the nailing flange of the sill in a manner that covers the nails and nail slots. Apply a minimum of 9" (229mm) wide horizontal sill flashing level with the bottom edge of the existing window by pressing the flashing into the sealant bead at its top edge. Cut the sill flashing long enough to extend a minimum of 9" (229mm) beyond each jamb. Fasten the sill flashing at the bottom and side edges.

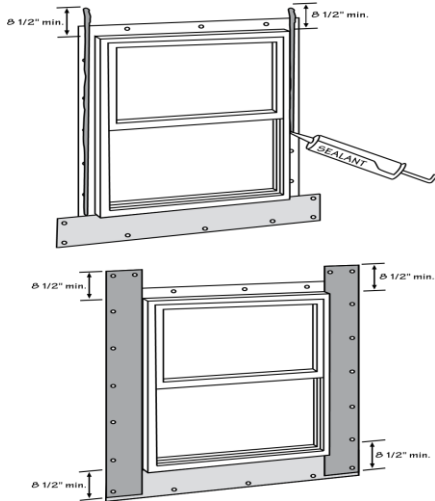

Apply a continuous bead of sealant to the nailing flange of the jambs in a manner that covers the nails and nail slots. Continue the bead of sealant at the jambs vertically a minimum of 8 1/2" (216mm) above the head of the window to allow for bedding the top portion of the jamb flashing into sealant in the next step. Install the jamb flashing by pressing the flashing into the sealant beads at the window jambs.

Extend the bottom edge of the jamb flashing approximately 1/2" (12.7mm) short of the sill flashing edge, and extend the top edge approximately 8 1/2" (216mm) beyond the head of the window, where the head flashing will be placed next. Fasten the jamb flashing along the edges further most from the window.

NOTE: Sealant should be compatible with window, flashing, and water-resistive barrier materials. Contact sealant manufacturer for job-specific recommendations.



Apply a continuous bead of sealant to the nailing flange of the head in a manner that covers the nails and nail slots. Add an additional bead of sealant horizontally, in line with the top of the head flashing. Install the head flashing by pressing the bottom edge of the flashing into the sealant bead previously applied across the mounting flange. Extend the ends of the head flashing approximately 1" (25.4mm) beyond the jamb flashing at each end. Fasten the head flashing into place along the top edge.

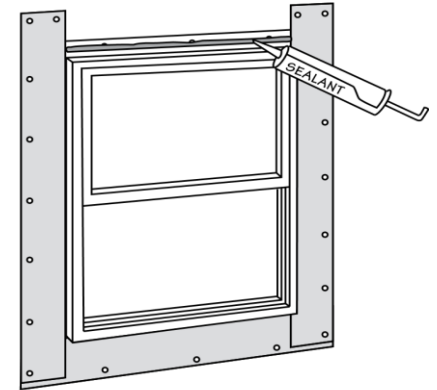

Flashing Previously Installed Window with Exterior Casing (Brick Mold)

If a window with exterior casing (e.g., brick mold) has been previously installed without flashing, the following instructions should be followed:

Ensure that exterior casing is sealed to the exterior sheathing or water-resistant barrier with a good quality sealant.

Cover the exterior casing with aluminum or vinyl trim sheet. This can be accomplished by using a portable field brake and bending instructions from the brake manufacturer. The trim sheet should be installed in weatherboard fashion. The bottom piece should be installed first, and each piece should overlap the piece below wherever they join.

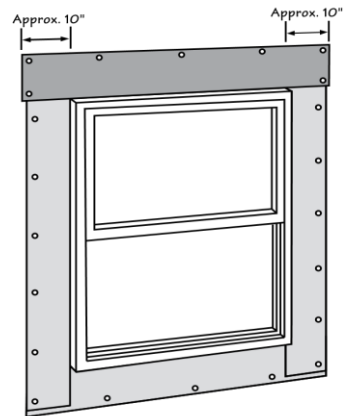

Install rigid head flashing (i.e., drip cap) on top of the top piece of exterior casing, covering trim sheet installed in the previous step. The ends of the rigid head flashing must extend to the outer edges of the exposed legs of the side J-channels. Cut a notch on the ends of the rigid head flashing and bend them down over the sides of the exterior casing. The rigid head flashing must be sealed to the exterior sheathing and to the top of the exterior casing.

Trim

J-channel is used around windows and doors to receive the siding. Follow the steps below when applying trim. Cut and bend the tab of the top piece of J-channel down to provide flashing over the side J-channel. Fold the bottom end of the side piece of J-channel inward at the bottom of the window, to fit over the existing J-channel to prevent water from entering under the sill.

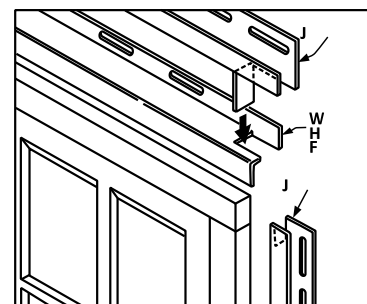



This *Siding and Insulation Requirements* handout illustrates proper flashing requirements around windows and doors. When siding is being installed on a residential home and when window/door trim is removed, proper flashing is required in accordance with the handout. Siding projects where the wood trim/jam around the window is not removed, the contractor will cover wood trim with aluminum, and flashing tape would not be required when the house wrap inspection is conducted. However, on an existing home when siding is being installed and wood trim is removed from around the window/doors the flange will be exposed and flashing tape is required. In this instance, flashing tape will be required by the inspector at the time of house wrap inspection.

WHAT YOU NEED TO APPLY

- A copy of the signed **contract** describing the cost of the project and the siding specifications
 - If the project is to be completed without contractor assistance, the property owner is to provide a detailed scope of work and materials list*
- Permit fee** (see chart below)

Estimated Cost of the Project	Permit Fee
Less than \$500.00	\$40.00
\$500.00 but less than \$1,000.00	45.00
\$1,000.00 but less than \$2,500.00	50.00
\$2,500.00 but less than \$5,000.00	60.00
\$5,000.00 but less than \$10,000.00	90.00
\$10,000.00 or more	12.00 per thousand

ADDITIONAL INFORMATION

- No work can begin until a building permit has been issued.
- If a **contractor** is performing the work, they **must be registered with the Village of Bartlett** as a licensed contractor.
- An **insulation inspection** is required upon completion of house wrap.
- A **final inspection** is required upon completion of work to close out the permit.
- All required inspections may be requested through the Village portal or by contacting the Building Division at 630-540-5920 at least 48 hours in advance.